

# FURRION

## DIGITAL WIRELESS OBSERVATION SYSTEM

FOS48TA-BL



**Vibrationsmart**  
Designed and tested  
For vibration resistance



**Climatesmart**  
Designed and tested  
For extreme climates



**Digital technology**  
100ft+ range digital  
Wireless technology



**Direct pairing**  
Uninterrupted direct  
digital pairing



- 5x signal stabilization and processing for high speed observation
- 12 Volt 4.3" multifunction LCD color display
- Water proof(IP65), 12 volt camera
- Digital wireless technology with direct monitor pairing
- External antenna for long distance signal transfer

- Shaded camera for low glare
- Wide angle lens
- Infrared night vision
- Adjustable camera angle
- Safety tested and FCC certified

FRCBRKT-BL mounting bracket is required. If the bracket is not pre-installed on your specialty vehicle you must purchase one separately. Available at [www.furrion.com](http://www.furrion.com)

## DIGITAL WIRELESS OBSERVATION SYSTEM FOS48TA-BL

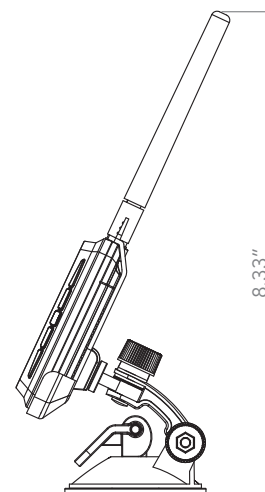
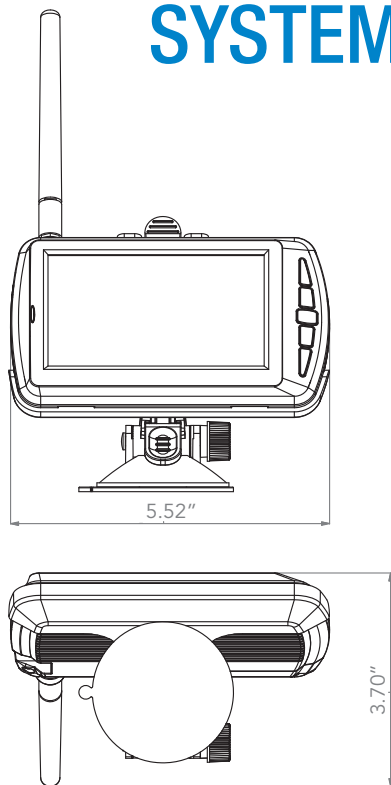
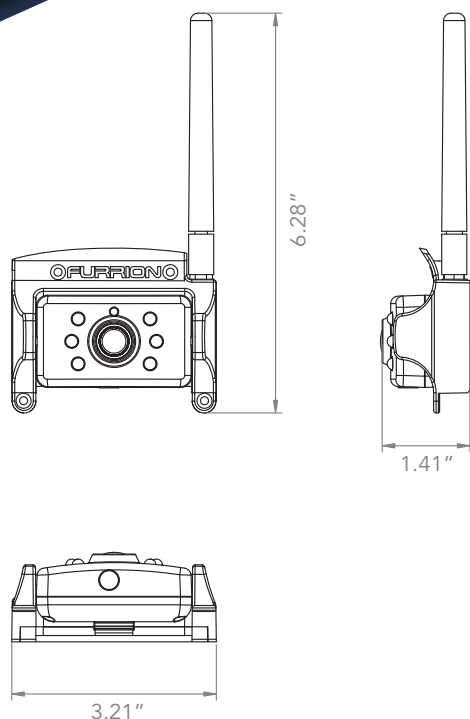

### Specifications

#### Camera

Input voltage	DC 8-30V
Input current	≤300mA
Wireless Range	≤300ft (outdoors)
Image Sensor	1/4" Color CMOS VGA
Camera	Max 25 frames/sec VGA f1.7mm, F2.0
IR	850nm filter View Distance≥1.5m Brightness ≤2Lux
Working Temperature	-10 °C~50 °C

#### Monitor

Input voltage	DC 8-30V
Input current	≤200mA
Standby Current	≤1mA
Wireless Range	≤300ft (outdoors)
Wireless Frequency	2.4Ghz
LCD Display	4.3" 480*272
Receiver Sensitivity	-78±3dBm
Working Temperature	-10 °C~50 °C

### Packaging Information

Packaging type	Color Gift Box
Quantity per level 1 (pcs)	1
Individual Packaging Dimensions	10.04"x2.36"x10.04"
Individual Packaging Gross Weight (kg)	0.6kg
Individual Packaging Net Weight (kg)	0.33kg

### Master Carton

Packaging type	Master Carton Box
Quantity per box	10
Master Carton Dimensions	20.67" x 13.39" x 10.83"
Master Carton Gross Weight (kg)	6.6kg
Master Carton Net Weight (kg)	3.3kg

